

ATX™ JBEA and ECEA Series Aluminum Enclosures

Increased Safety

ATEX/IECEX:
Zone 1 and 2 – 21 and 22
⊕ II 2 GD
IP66 – IK10

Applications

- Designed for use in Zone 1 or 2 areas where flammable gases or vapors are present either continuously or intermittently.
- Ideal for use in wet or corrosive atmospheres.
- Petroleum, chemical, refineries and other industrial process facilities.
- Designed for use in Zone 21 or 22 areas where flammable dusts are present either continuously or intermittently.
- Food processing, dairy, brewing and other commercial facilities.
- JBEA Series:
 - Terminal junction boxes for electrical low voltage and instrumentation connections in hazardous areas.
 - Refer to technical data to define permitted number of terminal blocks and cable entries on selected junction boxes.
- ECEA Series:
 - Enclosure for distribution and control applications can be customized at our workshop to house a large range of components; i.e. control units, switches, breakers, transformers, meters, etc.

Features

- Operating temperature:
 - PCe type: -55 °C to +60 °C (-67 °F to 140 °F)
 - CAe type: -40 °C to +55 °C (-40 °F to 131 °F)
- Rail mounting.
- Refer to technical data to define permitted number and size of terminals and cable entries.

Standard Materials

- Enclosure: gray painted grade marine aluminum alloy
- Hardware: stainless steel

Options

- Nameplates.
- Consult your local sales representative for:
 - Enclosures custom drilled and assembled at our factory.
 - Empty enclosure with Ex “U” component marking for re-certification by notified body for CAe type.

ATEX/IECEX Certifications and Compliances

- Certification Type PCe
 - Gas, Zones 1 and 2:
 - Conforming to ATEX 94/9/CE: ⊕ II 2 G
 - Type of Protection: Ex e II, Ex ia IIC, Ex ib IIC, Ex de IIC
 - Temperature class: T6 for Ta ≤ +40 °C (+104 °F), T5 for Ta ≤ +60 °C (+140 °F)
 - Dust, Zones 21 and 22:
 - Conforming to ATEX 94/9/CE: ⊕ II 2 D
 - Type of Protection: Ex tD A21
 - Surface Temperature: T80 °C to T95 °C (T176 °F to T203 °F)
 - Ambient Temperature: -55 °C to +60 °C (-67 °F to +140 °F)
 - CE Declaration of Conformity: 50221
 - ATEX Certificate: LCIE 00 ATEX 6047
 - Index of Protection according EN/IEC 60529: IP66
 - Impact Resistance (shock): IK10



PCe Type



CAe Type

- Certification Type CAe
 - Gas, Zones 1 and 2:
 - Conforming to ATEX 94/9/CE: ⊕ II 2 G
 - Type of Protection: Ex e II, Ex ia IIC, Ex ib IIC, Ex de IIC
 - Temperature Class: T6 to T2
 - Dust, Zones 21 and 22:
 - Conforming to ATEX 94/9/CE: ⊕ II 2 D
 - Type of Protection: Ex tD A21
 - Surface Temperature: T80 °C to T290 °C (T176 °F to T554 °F)
 - CE Declaration of Conformity: 50325
 - ATEX Certificate: LCIE 02 ATEX 6248X
 - IECEx Certificate: IECEx LCI 04.0016X
 - Index of Protection according EN/IEC 60529: IP66
 - Impact Resistance (shock): IK10
- Certification Type CAe U
 - Gas, Zones 1 and 2:
 - Conforming to ATEX 94/9/CE: ⊕ II 2 G
 - Type of Protection: Ex e II
 - Dust, Zones 21 and 22:
 - Conforming to ATEX 94/9/CE: ⊕ II 2 D
 - Type of Protection: Ex tD A21
 - Ambient Temperature: -40 °C to +55 °C (-40 °F to +131 °F)
 - CE Declaration of Conformity: 5C241
 - ATEX Certificate: LCIE 09 ATEX 3036 U
 - Index of Protection according EN/IEC 60529: IP66
 - Impact Resistance (shock): IK10

EURASEC Certification

- Certification Type PCe
 - EURASEC N° TC RU C-FR.Γ505.B.00911
- Certification Type CAe
 - EURASEC N° TC RU C-FR.Γ505.B.00911

ATX™ JBEA and ECEA Series Aluminum Enclosures

Increased Safety

ATEX/IECEX:
Zone 1 and 2 – 21 and 22
II 2 GD
IP66 – IK10

Catalog Numbering Guide – JBEA Series Aluminum Junction Box

JBEA	E	A	12	11	09	D1
JB Series ATEX/IECEX Certified Junction Box	Method of Protection: E - Increased Safety I - Intrinsic Safety	Material: A - Aluminum	Length Dimensions mm (in): 12 - 120 (4.72) 17 - 170 (6.69) 21 - 215 (8.47)	Width Dimensions mm (in): 11 - 110 (4.33) 20 - 205 (8.07) 38 - 380 (14.96)	Depth Dimensions mm (in): 09 - 91 (3.58) 13 - 130 (5.12) 19 - 190 (7.48)	Options: <i>(options must be listed alphabetically)</i> U - Component Certification "U" # - Customized Enclosure <i>(Digit number will be assigned at time of order placement)</i>

JBEA Series: Ex e II Aluminum Junction Boxes

For use with Ex certified terminals only (not supplied).
Mounting rails supplied.
Yellow laminated plastic label with black lettering.



ECEA Series: Aluminum Enclosure for Distribution and Control Applications

Designed to house a large range of components; i.e. control units, switches, breakers, transformers, meters, etc.
Must be customized at our workshop with the following Catalog Number:
Replace JB with EC, and add last digits and "#" for customized boxes. Example: ECEA 212013 #





Type	Dimensions L x W x D mm (in)	Rail Length Maximum Width mm (in)	Weight kg (lb)	Volume dm ³ (in ³)	Catalog Number	
					JBEA Series	ECEA Series
PCe1	120.0 x 110.0 x 95.0 (4.72 x 4.33 x 3.74)	94.0 (201.00)	1.0 (2.20)	2.2 (134.25)	JBEA121109	ECEA121109#
PCe2	170.0 x 110.0 x 95.0 (6.69 x 4.33 x 3.74)	144.0 (291.00)	1.3 (2.87)	2.7 (164.76)	JBEA171109	ECEA171109#
PCe3	230.0 x 110.0 x 95.0 (9.10 x 4.33 x 3.74)	204.0 (399.00)	1.6 (3.53)	5.2 (317.32)	JBEA231109	ECEA231109#
CAe1	215.0 x 205.0 x 130.0 (8.47 x 8.07 x 5.12)	191.0 (376.00)	4.0 (8.82)	13.0 (793.30)	JBEA212013	ECEA212013#
CAe2	320.0 x 205.0 x 130.0 (12.60 x 8.07 x 5.12)	293.0 (559.00)	5.0 (11.02)	23.0 (1403.60)	JBEA322013	ECEA322013#
CAe3	425.0 x 205.0 x 130.0 (17.80 x 8.07 x 5.12)	400.0 (752.00)	6.0 (13.28)	33.0 (2013.80)	JBEA422013	ECEA422013#
CAe5	480.0 x 380.0 x 190.0 (18.90 x 14.96 x 7.48)	335.0 (635.00)	11.0 (24.25)	53.0 (3234.30)	JBEA483819	ECEA483819#

ATX™ JBEA and ECEA Series Aluminum Enclosures

Increased Safety

ATEX/IECEX:
 Zone 1 and 2 – 21 and 22
 II 2 GD
 IP66 – IK10

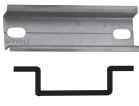
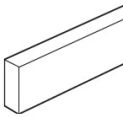
Accessories

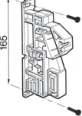
		Enclosure Type	Rail Length mm (in)	Catalog Number	Pack
	Zinc Plated Symmetrical Steel Rail For direct fixing. Set of two 60 mm (2.36") height spacers supplied.	CAe1	191 (7.52)	JBEPDR215	1
		CAe2	293 (11.54)	JBEPDR320	1
		CAe3	400 (15.75)	JBEPDR425	1
	Copper Bar – 12 x 4 mm (0.47 x 0.16") Copper bar not perforated for cable clamps.		Bar Length mm (in)	Catalog Number	Pack
			160 (6.30)	097270	1
			200 (7.87)	097271	1
			310 (12.20)	097272	1
			500 (19.68)	097273	1
	690 (27.17)	097274	1		
	Cable Clamp for Copper Bar – 12 x 4 mm (0.47 x 0.16") 1.5 mm ² to 4 mm ² (0.002 in ² to 0.006 in ²) capacity. 6 mm ² to 16 mm ² (0.009 in ² to 0.025 in ²) capacity.			097203	1
				097204	1
	Insulated Side Support – Set of Two For mounting symmetrical, asymmetrical rails and copper bar 12 x 2 mm (0.47 x 0.08") or 12 x 4 mm (0.47 x 0.16"). See dimensional data page for more details.			096115	1

JBEA Series for Junction Box Application Only.

The size of the junction box needed to meet your requirements can be selected based on the table shown below. We also offer you the possibility to drill and equip, please consult our drilling guide available online at: www.appletonelec.com

1. Define maximum cable entries according to number of modules available per side.

Cable Entry Metric Thread	Number of Modules
M20	1
M25	1
M32	1
M40	2
M50	3

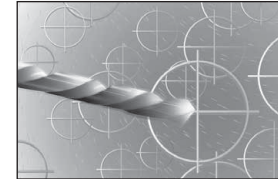
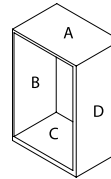

Type	Length	Dimensions mm (in)			Number of Modules		Allowable Max. Size	Terminal Dim. H — mm (in)
		Width	Depth	A/C	B/B			
PCe1	120 (4.72)	110 (4.33)	95 (3.74)	2	2	M25	110 (4.33)	
PCe2	170 (6.69)	110 (4.33)	95 (3.74)	2	3	M32	110 (4.33)	
PCe3	230 (8.46)	110 (4.33)	95 (3.74)	2	4	M32	110 (4.33)	
CAe1	215 (8.47)	205 (8.07)	130 (5.12)	11	8	M50	205 (8.07)	
CAe2	320 (12.60)	205 (8.07)	130 (5.12)	18	8	M50	205 (8.07)	
CAe3	425 (16.73)	205 (8.07)	130 (5.12)	26	8	M50	205 (8.07)	
CAe5	575 (22.64)	380 (14.96)	190 (7.48)	34	25	M50	380 (14.96)	

2. Maximum Rail Arrangement According to Physical Dimensions — Maximum Quantity of Horizontal Rails

Type	Terminal Capacity mm ² (in ²)						
	2.5 (0.0039)	4.0 (0.0062)	6.0 (0.0093)	10.0 (0.0155)	16.0 (0.0248)	35.0 (0.0543)	50.0 (0.0775)
PCe1/2/3	1	1	1	1	0	0	0
CAe1/2/3	1	1	1	1	1	1	0
CAe5	3	3	2	2	2	1	1

ATX™ JBEA and ECEA Series Aluminum Enclosures

Increased Safety

ATEX/IECEX:
 Zone 1 and 2 – 21 and 22
 II 2 GD
 IP66 – IK10

3. Defining maximum terminal block quantity according to power dissipation:

- Junction boxes used for instrumentation applications have very low current levels, therefore there is no risk of overheating whatever the number of terminals inside the box.
- For applications other than instrumentation, the following tables allow you to define your junction box depending on the number of terminals and the maximum authorized current being carried with feed-through terminals.
- For single feed terminals using cross connection, please consult your local representative for a calculation.

For other terminal block configurations, please consult our drilling guide available online at: www.appletonelec.com

T Rating: T6		Type		
		CSPe1 120 x 120 x 91 mm (5 x 5 x 4")	CSPe2 120 x 170 x 91 mm (7 x 5 x 4")	CSPe3 120 x 230 x 91 mm (9 x 5 x 4")
2.5 mm ² (0.004 in ²)	Quantity	12	22	33
	I Maximum	15 A	13 A	12 A
4.0 mm ² (0.006 in ²)	Quantity	10	18	28
	I Maximum	20 A	19 A	16 A
6.0 mm ² (0.009 in ²)	Quantity	7	14	21
	I Maximum	32 A	27 A	24 A
10.0 mm ² (0.016 in ²)	Quantity	4	6	8
	I Maximum	50 A	50 A	50 A

T Rating: T6 @ Ta +40 °C (+104 °F) T5 @ Ta +55° C (+131 °F)		Type			
		CAe1 200 x 215 x 150 mm (8 x 9 x 6")	CAe2 200 x 320 x 150 mm (8 x 13 x 6")	CAe3 200 x 425 x 150 mm (8 x 17 x 6")	CAe4 200 x 575 x 150 mm (8 x 23 x 6")
2.5 mm ² (0.004 in ²)	Quantity	20	21	23	38
	I Maximum	16 A	16 A	16 A	16 A
4.0 mm ² (0.006 in ²)	Quantity	19	20	23	38
	I Maximum	20 A	20 A	20 A	20 A
6.0 mm ² (0.009 in ²)	Quantity	12	13	14	23
	I Maximum	32 A	32 A	32 A	32 A
10.0 mm ² (0.016 in ²)	Quantity	10	11	18	30
	I Maximum	40 A	40 A	32 A	32 A
16.0 mm ² (0.024 in ²)	Quantity	8	10	13	22
	I Maximum	28 A	27 A	25 A	26 A
25.0 mm ² (0.039 in ²)	Quantity	8	8	10	20
	I Maximum	67 A	73 A	69 A	60 A
35.0 mm ² (0.054 in ²)	Quantity	8	8	10	12
	I Maximum	79 A	86 A	80 A	100 A

ATX™ JBEA and ECEA Series Aluminum Enclosure

Increased Safety

ATEX/IECEX:
 Zone 1 and 2 – 21 and 22
 II 2 GD
 IP66 – IK10

Dimensions in Millimeters (Inches)

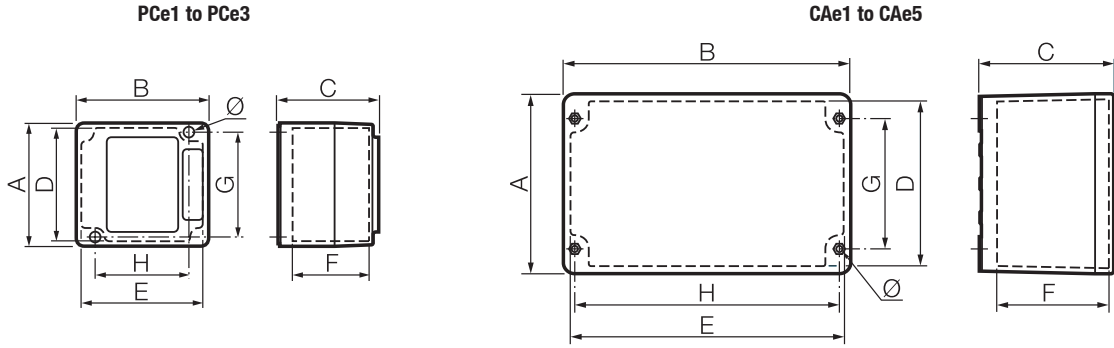

Type	External			Internal				Fixings		
	A	B	C	D	E	F	G	H	Thick	Ø
PCe1	110 (4.33)	120 (4.72)	95 (3.74)	100 (3.94)	110 (4.33)	70 (2.76)	94 (3.70)	84 (3.31)	20 (0.79)	5.0 (0.20)
PCe2	110 (4.33)	170 (6.69)	95 (3.74)	100 (3.94)	160 (6.30)	70 (2.76)	94 (3.70)	134 (5.28)	20 (0.79)	5.0 (0.20)
PCe3	110 (4.33)	230 (9.10)	95 (3.74)	100 (3.94)	220 (8.66)	70 (2.76)	94 (3.70)	194 (7.64)	20 (0.79)	5.0 (0.20)
CAe1	205 (8.07)	215 (8.47)	130 (5.12)	190 (7.48)	200 (7.87)	105 (4.13)	146 (5.75)	186 (7.32)	10 (0.39)	6.5 (0.26)
CAe2	205 (8.07)	320 (12.60)	130 (5.12)	190 (7.48)	305 (12.01)	105 (4.13)	146 (5.75)	290 (11.42)	10 (0.39)	6.5 (0.26)
CAe3	205 (8.07)	425 (17.80)	130 (5.12)	190 (7.48)	410 (16.14)	105 (4.13)	146 (5.75)	398 (15.67)	10 (0.39)	6.5 (0.26)
CAe5	480 (18.90)	380 (14.96)	190 (7.48)	378 (14.88)	279 (10.98)	132 (5.20)	385 (15.16)	285 (11.22)	13 (0.51)	7.0 (0.28)

Insulated Side Support (Rail Holder) 096115

Type	Equipment Capacity	
	L	M
CAe1	105 (4.13)	129 (5.08)
CAe2	206 (8.11)	234 (9.21)
CAe3	310 (12.20)	339 (13.35)
CAe5	315 (12.40)	345 (13.58)

